

PowerOptimal Elon® 100 Installation Checklist V1.03

NOTE: This Installation Checklist is intended for installers and not general users. Users should please refer to the User Manual, which can be found at www.poweroptimal.com/manuals. This is NOT a replacement for the Installation Manual. Installers must follow the installation instructions in the Installation Manual, which can be found at the above link. **All Elon installations must be signed off by a registered electrician, who must issue a supplementary CoC.**

Customer name		Date		Elon® serial no.	
Installation address					
Installer name			Installer signature		

1. **INSTALLATION INSPECTION CHECKLIST**

No.	Action	Result	Units
DC Side Inspection (NOT a full solar PV installation checklist - we recommend PV GreenCard)			
1	Check that all panels are mounted securely	<input type="checkbox"/>	
2	Check that mounting structure is grounded	<input type="checkbox"/>	
3	Check that all panels are the same power rating and model	<input type="checkbox"/>	
4	Check all insulation on PV cables	<input type="checkbox"/>	
5	Check that PV cable size is as specified for installation	<input type="checkbox"/>	
6	Check that all connectors are securely fastened	<input type="checkbox"/>	
7	Check that all PV cables are properly routed and secured	<input type="checkbox"/>	

No.	Action	Result	Units
8	Check that DC circuit breaker OR DC isolator + fuse are installed within 2m of geyser & in line of sight	☐☐	
9	Check that no PV cables are coiled	☐☐	
10	Check that PV cables are connected to the solar input terminals on the Elon 100 and with correct polarity (see wiring diagram on last page)	☐☐	
AC Side Inspection			
11	Check that AC isolator is installed within 2m of geyser & in line of sight	☐☐	
12	Check that AC wires are connected to the correct terminals on the Elon 100 (see wiring diagram on last page)	☐☐	
Elon 100 inspection			
13	Check that Elon is installed within 2m of geyser (maximum wire length between Elon and geyser is 3m). If installed outside, the Elon should be protected from the elements and installed with glands facing downward.	☐☐	
14	Check that two wires run between the Elon's "element" terminals and the "element" terminals on the green element adapter and that they are securely connected at both ends.	☐☐	
15	Check that two wires run between the Elon's "thermostat" terminals and the thermostat, and that they are securely connected at both ends.	☐☐	
16	Check that all wiring is at least 2.5mm ²	☐☐	

No.	Action	Result	Units
17	IMPORTANT: Check that element adapter's male spade terminals are securely and correctly seated in the element's female terminals. Do a tug test on each side to test that it is secure.	<input type="checkbox"/>	
18	Check that ALL labels have been applied as per the label diagram in the Elon installation manual (installation diagram, "Warning! photovoltaic power source" and 2 x "Warning, Dual Supply").	<input type="checkbox"/>	
19	Check that controller (remote control) has been securely installed in an accessible place and that both ends of the communication cable are properly inserted.	<input type="checkbox"/>	

1. COMMISSIONING CHECKLIST (DC Clamp Meter required)

No.	Action	Result	Units
20	Confirm correct wiring and confirm DC polarity to Elon® as per basic wiring diagram after this table. Also confirm test meter wires are connected correctly, black to common!	<input type="checkbox"/>	
21	Confirm correct voltages and currents of all connections through the following steps:		
21a	Confirm open / closed thermostat voltages (11 - 14 V DC open, 0 V DC closed). Leave thermostat in closed position for rest of testing. If water is already at setpoint (e.g. 55 or 60		V DC (open)

No.	Action	Result	Units
	V DC (closed)		
21b	Confirm controller wire is connected properly. The connections should “click” into place and appropriate LEDs should indicate (be active).	☐	
21c	With dial on “SOLAR ONLY” and solar power flowing to element (green LED flashing), confirm same DC voltage to element as measured at solar terminals.		V DC solar
			V DC element
21d	With DC clamp meter confirm that there is an active current through element by measuring the current of one of the wires going from Elon® to element.		A DC
21e	Turn dial to “MAINS ONLY”. Note that the Elon® will only switch to mains 5 min after mains power switch-on or reconnection. With mains power flowing to element (red LED flashing), confirm same AC voltage to element as measured at mains terminals (should be approx. 230V AC).		V AC mains
			V AC element
21f	With AC clamp meter confirm active current through element of between 9 and 18 Amps depending on element rating.		A AC
22	If you used a test controller for commissioning, remember to plug the wire from the installed controller back into the Elon® and check functioning.	☐	
23	Set thermostat back to original setting.	☐	

No.	Action	Result	Units
24	Set control dial to setting “ 2” (the 6 o’clock position).	☐	

Basic wiring diagram for Elon® 100

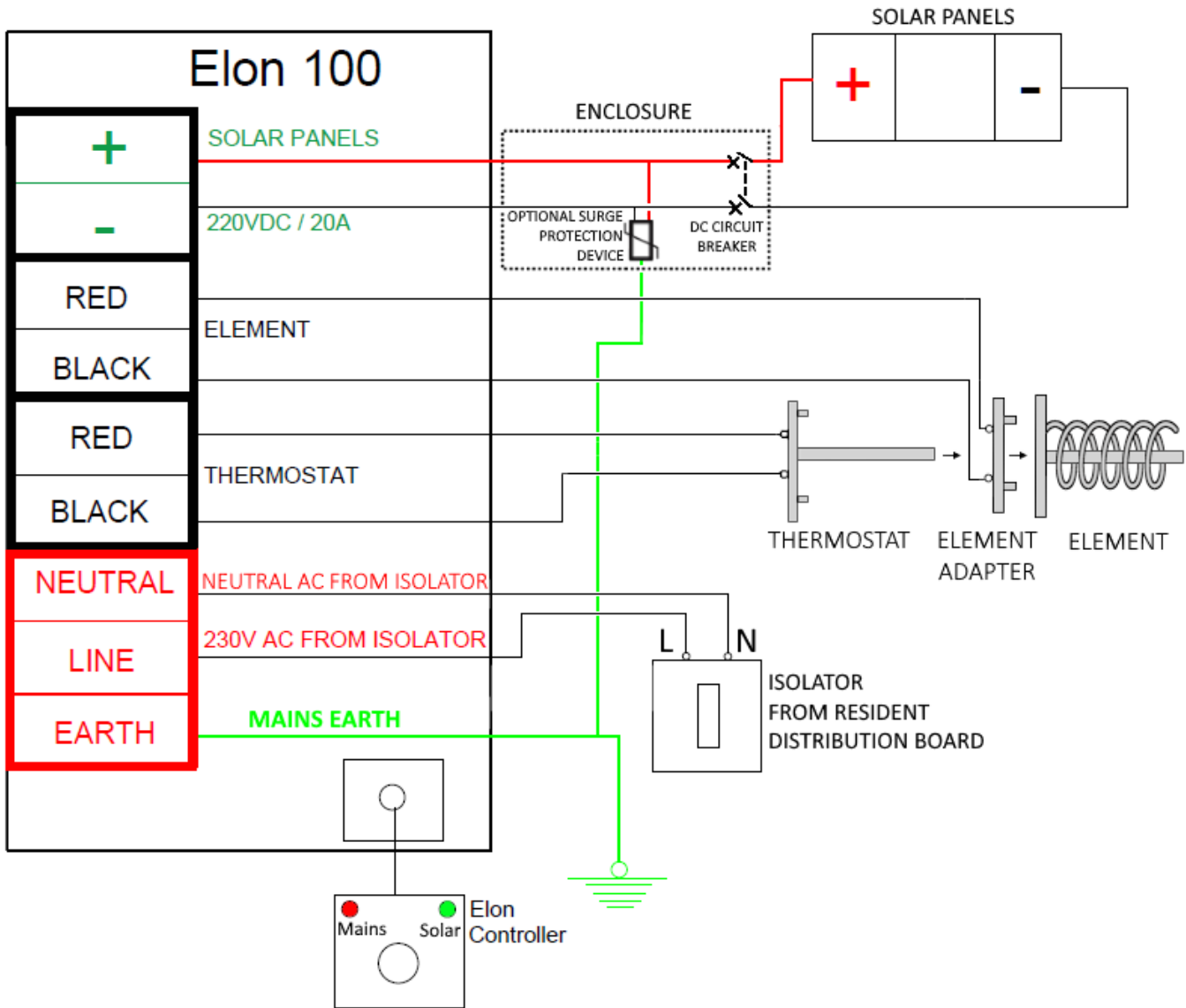

Things to Remember

- The **red mains LED** will only start functioning once stable mains voltage between 190 and 260 V AC is present for more than **5 minutes**. (In other words, the Elon® will only allow mains power to the element 5 minutes after mains connection or switch-on.)
- **Solar power** is only recognised **40 seconds** after active solar panels are connected to Elon®.
- An **open thermostat** (water at correct temperature) measures between **11 and 14 V DC** across the “thermostat” terminals on the Elon®. Polarity across these terminals is not important.
- A **closed thermostat** (cold water) **measures 0 V** across the “thermostat” terminals on the Elon®.

- **How to switch on solar power to element:** With enough solar energy (check at solar terminals), solar power will be routed to the element within 15 seconds after the thermostat closes and the controller dial is set to “**SOLAR ONLY**”. A green flashing LED indicates this condition.
 - **How to switch on mains power to element:** Turn control dial to “**MAINS ONLY**” and, if the thermostat is closed, mains power will be directed to the element indicated by a red flashing LED.
 - **Note:** Once the dial has been turned to “**MAINS ONLY**”, it will complete a full mains heating cycle (until the thermostat opens). Turning the control back to “**SOLAR ONLY**” at this point **will NOT immediately switch the unit back to solar power**. It will only switch back again after the mains heating cycle is completed (i.e. the thermostat opens) and the thermostat then closes again. You can finish the mains heating cycle faster by reducing the thermostat temperature setting until the thermostat opens. **Test solar power first.**
-

Revision #1

Created 2026-06-10 03:59:23 UTC by Sean Moolman

Updated 2026-06-10 03:59:23 UTC by Sean Moolman